

KRONOS

BRIDGE TYPE CNC COORDINATE MEASURING MACHINE

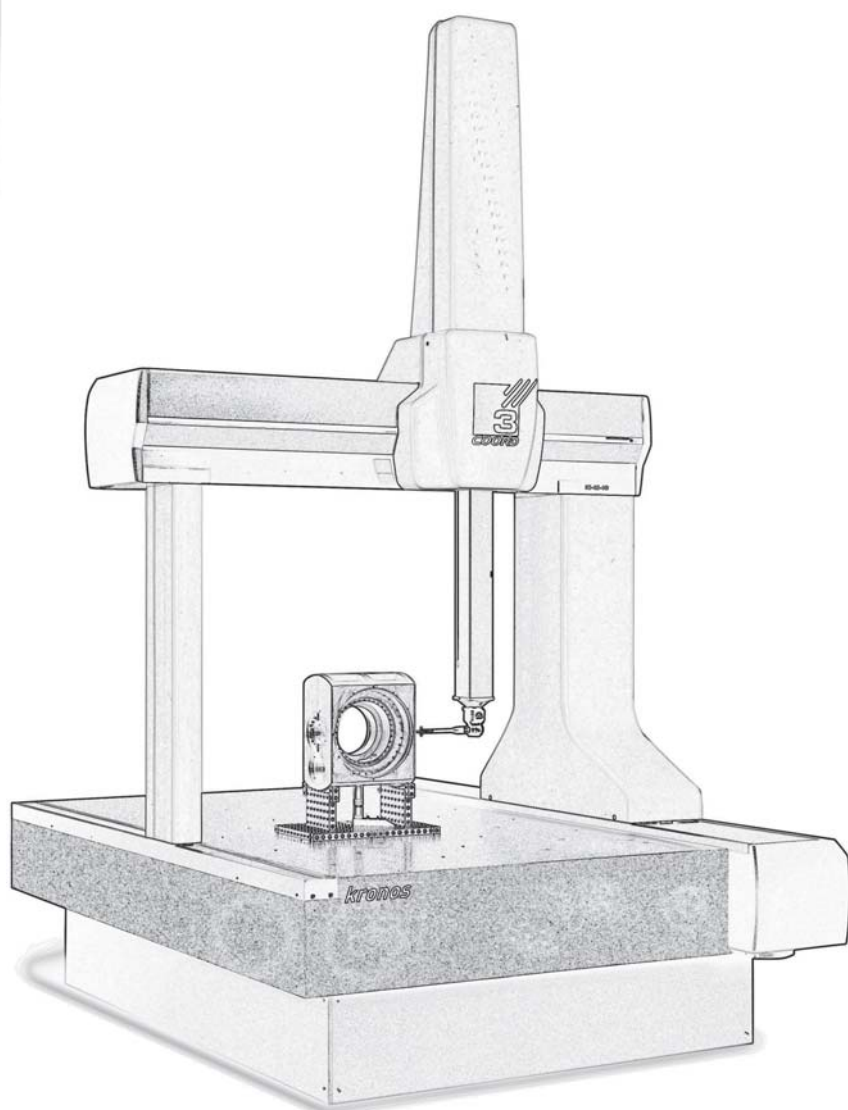

KRONOS 13.10-15.13

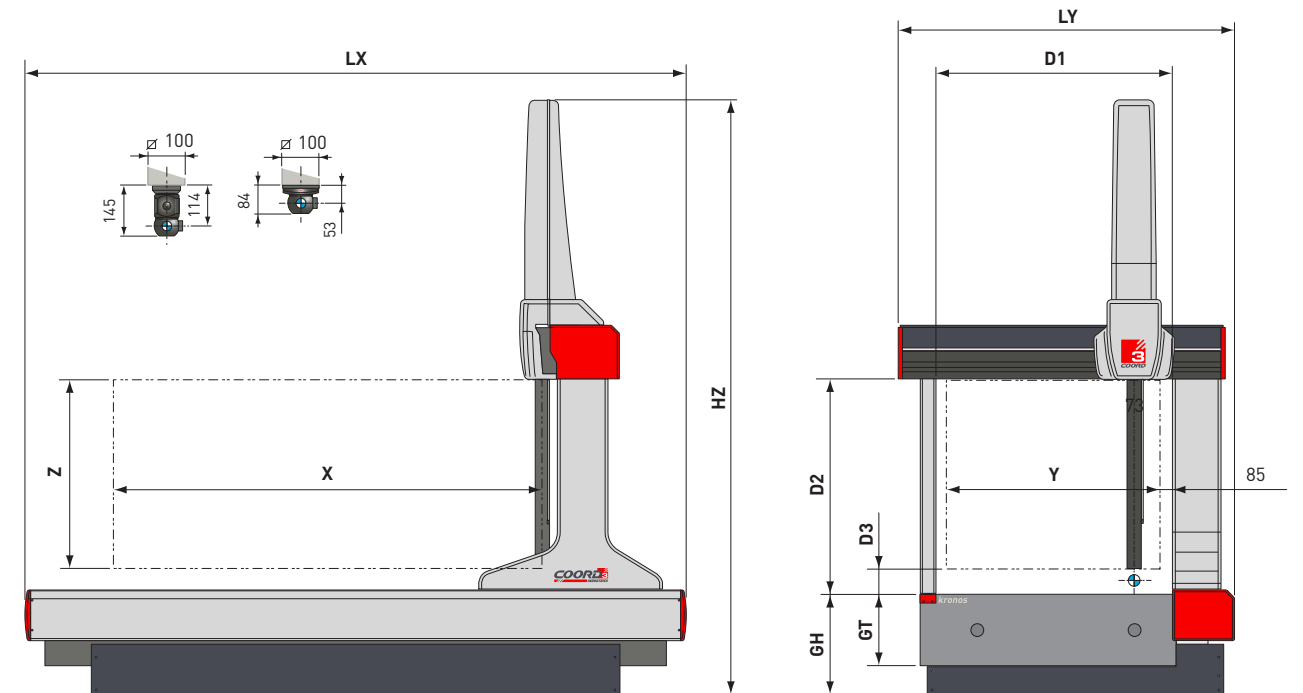

PERFORMANCE

Models	Maximum Permissible Error ISO 10360-2 / ISO 10360-4 MPE [μm], L [mm], t [sec]															Max. 3D Pos. Speed	Max. 3D Accel.
	T ₁ : 18±22 °C							T ₂ : 16±26 °C									
	PH10M-TP2/TP20		PH10MQ-TP200		PH10MQ-SP25			PH10M-TP2/TP20		PH10MQ-TP200		PH10MQ-SP25					
	⁽¹⁾ MPE _E	⁽²⁾ MPE _P	⁽¹⁾ MPE _E	⁽²⁾ MPE _P	⁽¹⁾ MPE _E	⁽²⁾ MPE _P	⁽³⁾ MPE _{THP}	⁽¹⁾ MPE _E	⁽²⁾ MPE _P	⁽¹⁾ MPE _E	⁽²⁾ MPE _P	⁽¹⁾ MPE _E	⁽²⁾ MPE _P	⁽³⁾ MPE _{THP}			
[μm]		[μm]		[μm]			[μm]		[μm]		[μm]				[mm/s]	[mm/s ²]	
xx.13.10	3,7 + L/250	3,7	3,5 + L/250	3,5	3,3 + L/250	3,3	6,5/120	3,7 + L/143	3,7	3,5 + L/143	3,5	3,3 + L/143	3,3	6,5/120	700	1300	
xx.15.13	5,0 + L/200	5,0	4,5 + L/200	4,5	4,0 + L/200	4,0	8,0/120	5,0 + L/143	5,0	4,5 + L/143	4,5	4,0 + L/143	4,0	8,0/120	700	950	
30.15.13	5,0 + L/200	5,0	4,5 + L/200	4,5	4,0 + L/200	4,0	8,0/120	5,0 + L/133	5,0	4,5 + L/133	4,5	4,0 + L/133	4,0	8,0/120	700	950	

Performance data are only valid if the following specifications are met:
 - PH10T/PH10M/PH10MQ/TP20/TP200: Tip diameter $\varnothing 4$ mm x Stylus length 20 mm
 - PH10MQ/SP25: SM1, Stylus $\varnothing 5$ mm x 50 mm
 - L = measuring length in mm
 - Ambient temperature:

T₁: 18 ± 22 °C; Max. Gradients: 1,0 °C/h - 2,0 °C/24h - 0,5 °C/m
 T₂: 16 ± 26 °C; Max. Gradients: 1,0 °C/h - 5,0 °C/24h - 1,0 °C/m

⁽¹⁾ According to ISO 10360-2, Error of indication of a CMM for size measurement

⁽²⁾ According to ISO 10360-2, Probing Error

⁽³⁾ Scanning probing error according to ISO 10360-4 applicable to the SP25/SP80 probes only

STROKES, DIMENSIONS, WEIGHTS

Models	Measuring Strokes			Overall Dimensions ⁽⁴⁾			Surface Plate				Daylights			Weights	
	X	Y	Z	LX	LY	HZ	Height	Thickness	M8 Hole Pattern		D1	D2	D3	Max. Part Weight	Machine Weight
	[mm]			[mm]			[mm]		[mm]		[mm]			[kg]	
20.13.10	2000	1300	1000	3630	2154	3560	700	360	250	250	1455	1208	166	4000	4200
20.15.13	2000	1500	1300	3630	2354	4160	700	360	250	250	1655	1508	180	4500	4770
25.15.13	2500	1500	1300	4130	2354	4160	700	400	300	300	1655	1508	180	5000	5550
30.15.13	3000	1500	1300	4630	2354	4160	700	500	300	300	1655	1508	180	5000	7550

For detailed dimensions refers to the installation drawings.

⁽⁴⁾ Table (900 x 700 mm) and control cabinet (600 x 600 x 1096 mm) not included

KRONOS 20.15

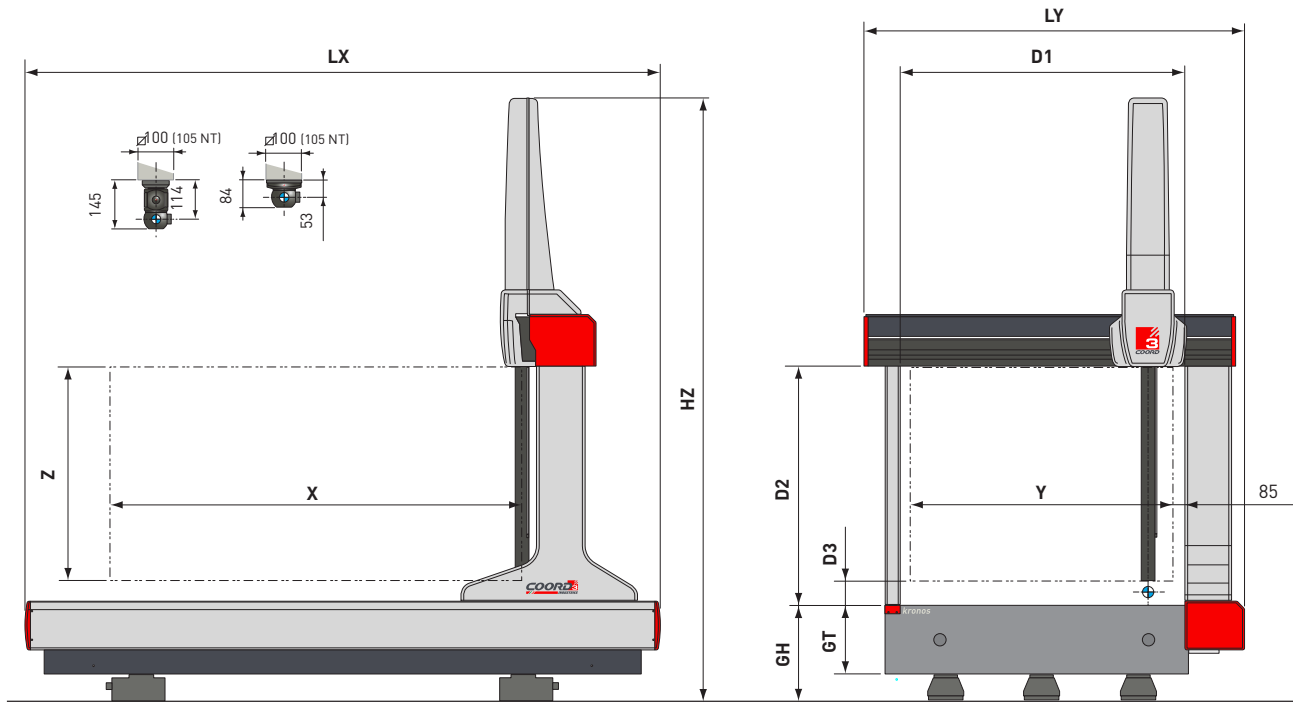

PERFORMANCE

Models	Maximum Permissible Error ISO 10360-2 / ISO 10360-4															Max. 3D Pos. Speed	Max. 3D Accel.
	MPE [μm], L [mm], t [sec]																
	$T_1: 18 \pm 2 \text{ } ^\circ\text{C}$									$T_2: 16 \pm 26 \text{ } ^\circ\text{C}$							
	PH10M-TP2/TP20			PH10MQ-TP200		PH10MQ-SP25			PH10M-TP2/TP20		PH10MQ-TP200		PH10MQ-SP25				
⁽¹⁾ MPE _E	⁽²⁾ MPE _P		⁽¹⁾ MPE _E	⁽²⁾ MPE _P	⁽¹⁾ MPE _E	⁽²⁾ MPE _P	⁽³⁾ MPE _{THP}	⁽¹⁾ MPE _E	⁽²⁾ MPE _P	⁽¹⁾ MPE _E	⁽²⁾ MPE _P	⁽¹⁾ MPE _E	⁽²⁾ MPE _P	⁽³⁾ MPE _{THP}			
[μm]			[μm]		[μm]			[μm]		[μm]		[μm]			[mm/s]	[mm/s ²]	
xx.20.15	6,5 + L/200	6,5		5,5 + L/200	5,5	5,2 + L/200	5,2	10,0/120	6,5 + L/133	6,5	5,5 + L/133	5,5	5,2 + L/133	5,2	10,0/120	500	800

Performance data are only valid if the following specifications are met:

- PH10T/PH10M/PH10MQ/TP20/TP200: Tip diameter $\varnothing 4 \text{ mm}$ x Stylus length 20 mm
- PH10MQ/SP25: SM1, Stylus $\varnothing 5 \text{ mm}$ x 50 mm.

- L = measuring length in mm

- Ambient temperature:

$T_1: 18 \pm 2 \text{ } ^\circ\text{C}$; Max. Gradients: 1,0 $^\circ\text{C/h}$ - 2,0 $^\circ\text{C}/24\text{h}$ - 0,5 $^\circ\text{C/m}$

$T_2: 16 \pm 26 \text{ } ^\circ\text{C}$; Max. Gradients: 1,0 $^\circ\text{C/h}$ - 5,0 $^\circ\text{C}/24\text{h}$ - 1,0 $^\circ\text{C/m}$

⁽¹⁾ According to ISO 10360-2, Error of indication of a CMM for size measurement

⁽²⁾ According to ISO 10360-2, Probing Error

⁽³⁾ Scanning probing error according to ISO 10360-4 applicable to the SP25/SP80 probes only

STROKES, DIMENSIONS, WEIGHTS

Models	Measuring Strokes			Overall Dimensions ⁽⁴⁾			Surface Plate				Daylights			Weights	
	X	Y	Z	LX	LY	HZ	Height	Thickness	M8 Hole Pattern		D1	D2	D3	Max. Part Weight	Machine Weight
	[mm]			[mm]			[mm]		[mm]		[mm]			[kg]	
33.20.15	3300	2000	1500	4930	2854	4470	610	450	400	400	2155	1708	166	5000	14550
40.20.15	4000	2000	1500	5930	2898	4512	650	450	400	400	2155	1708	166	5000	20000
50.20.15	5000	2000	1500	6930	2898	4512	650	450	400	400	2155	1708	166	5000	21000

For detailed dimensions refers to the installation drawings.

⁽⁴⁾ Table (900 x 700 mm) and control cabinet (600 x 600 x 1096 mm) not included

STRUCTURE

Coordinate Measuring Machine, CNC type, with mobile bridge structure on granite table machine base

Guideways:

X Axis: dovetail guideways, machined into the granite table
Y/Z Axes: micromachined anodized light alloy extrusion

Drive Method:

X axis: zero hysteresis friction drive (20.13.10/20.15.13), rack & pinion system
Y axis: zero hysteresis friction drive
Z axis: zero hysteresis friction drive

Sliding System:

Air bearings on all axes

Motion Control:

DC servomotor on all axes

Thermal Compensation:

Multi-sensors temperature compensation system for part and scale

Measuring System:

Linear scales, System Resolution: 0,5 µm

PROBING SYSTEM

Manual Probe Head:

MIH / MH20 / MH20i

Motorized Probe Head:

PH10T, PH10M, PH10MQ

Point-to-point Trigger Probe:

TP2, TP20, TP200

Analog Contact Probe:

SP25 (Optional)

Laser Probe:

Metris LC/XC series (qualification sphere included)

Stylus and Probe Changer:

Fully automated stylus and probe changers

CONTROL UNIT

Terminal Unit is used by the operator to manually control the motorized measuring machine (ArKey).

The controller features the continuous interpolation of axes motion for cycle time optimization.

Optional

- Index/continuous Rotary Table

WARRANTY

12 months from the date of acceptance test or a maximum of 15 months from date of shipment

ENVIRONMENT

Temperature Range for Metrological Specification:

T₁: Temperature Range: 18 ÷ 22 °C
Max. gradient per hour: 1,0 °C/h
Max. gradient per day: 2,0 °C/24h
Max. gradient in space: 0,5 °C/m
T₂: Temperature Range: 16 ÷ 26 °C
Max. gradient per hour: 1,0 °C/h
Max. gradient per day: 5,0 °C/24h
Max. gradient in space: 1,0 °C/m

Operating Temperature:

15 ÷ 35 °C

Relative Humidity:

40 ÷ 80 % (non condensing)

Acceptable Vibrations:

(vibration acceleration between peaks)
30 mm/s² from 1 to 10 Hz
15 mm/s² from 10 to 20 Hz
50 mm/s² from 20 to 100 Hz

Optional

- Metrology Room or CMM protection system

AIR SUPPLY

Air Consumption:

160 Nl/min

Minimum Air Supply:

6 Bar (79 PSI)

POWER SUPPLY

Power Supply Voltage:

230 V ± 10%; 50 Hz ± 2% (single phase)

Maximum Power Consumption:

10A 1600 W

(data for CC3 controller only)

Optional

- Voltage: 115 V ± 10%; 60 Hz ± 2% (single phase)

OPTION

Passive vibration insulating system
Active vibration insulation system (AVM)
Multi-wire cable
Loading/unloading pallet system, manual or automatic
PC & Printer
Training c/o Coord3 Center or Agents
Installation by Coord3 or Agents personnel



Coord3 Industries S.r.l.

Headquarters/Administration and Sales:

Strada Statale 25, n. 3
10050 Bruzolo (TO) - Italia
Tel.: +39 011 9635511 | Fax: +39 011 9635566
info@coord3.it
www.coord3.it | www.coord3-cmm.com

Italian offices:

Via B Diotti, 21
20153 Milano - Italia
Tel.: +39 02 47999197
Fax: +39 02 47997754

Via degli Oleandri, 8
51100 Loc. Nespolo
Chianciano (PT) - Italia
Tel.: +39 0573 935058
Fax: +39 0573 539970

Full list of Agents & Distributors available at www.coord3.it